

Date of Purchase ___ / ___ / ___
Lot Number:

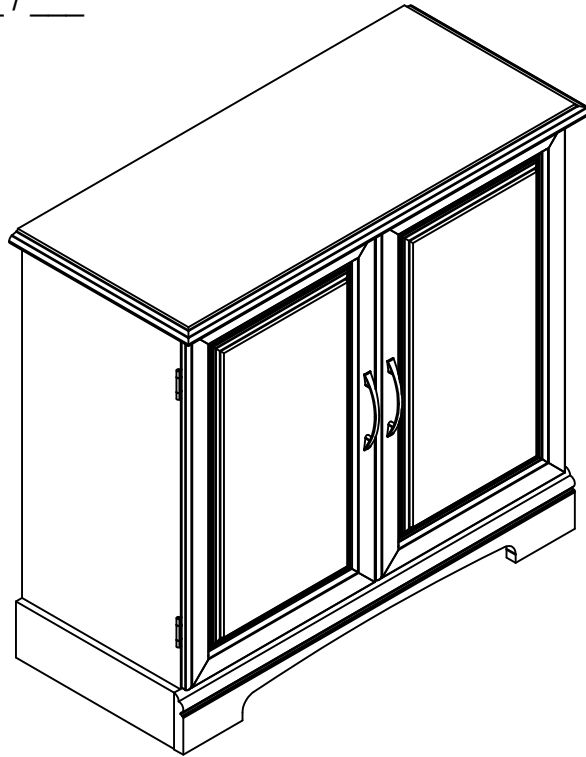

DO NOT RETURN PRODUCT TO THE STORE
Individual stores do not stock parts.

NO REGRESAS ESTA PRODUCTO A LA TIENDA
Las tiendas no tiene partes.

NE RETOURNEZ PAS LE PRODUIT AU MAGASIN
Les magasins individuels ne gardent pas de pièces.

If a part is missing or damaged, please visit our website or call our toll-free customer service line. We will gladly ship your replacement parts FREE of charge.

Si las partes están perdidas o dañadas Por favor visite nuestra página de Internet o llame a nuestra línea de teléfono gratis de Servicio al Cliente. Nosotros le enviaremos sus repuestos sin cargo adicional, serán totalmente gratis.

Si une pièce est manquante ou endommagée, veuillez visiter notre site web ou appelez sans frais notre Service à la clientèle. Nous expédierons avec plaisir vos pièces de rechange GRATUITEMENT.

Need Parts or Assistance?

Nesacitas partes o Asistencia?

Besoin de Pièces ou d'assistance?

WWW.AMERIWOODHOME.COM/PARTS

or call toll free:
o llame a nuestra línea gratis: 1-800-489-3351
ou appelez sans frais:

For prompt, reliable service; please have your assembly manual ready.

Para servicio mas rapido y reliable por favor tenga esta manual listo.

Pour un service rapide et fiable, s'il vous plaît ayez votre livret d'assemblage en main.

This instruction booklet contains **IMPORTANT** safety information.
Please read and keep for future reference.

-KEEP FOR REFERENCE-

-GUARDAR PARA REFERENCIA-

-GARDEZ POUR RÉFÉRENCE-

⚠️ WARNING



Unit can tip over causing severe injury or death.

- Anchor unit to stud or wall.
- **DO NOT** allow children to climb on unit.
- Put heavy items on lower shelves or drawers.
- Read and follow all assembly instructions.

⚠️ ADVERTENCIA

Este mueble puede caerse por encima causando daño serio o la muerte

- Anolar el mueble a un espárrago muro.
- **NO** dejar que los niños suben por encima del mueble.
- Poner los articulos mas pesados en los tableros o cajones inferiores.
- Leer y seguir todos de los instuccionnes para el montaje.

⚠️ AVERTISSEMENT

L'unité peut basculer et causer des blessures graves ou la mort.

- Fixez l'unité au mur ou à un montant.
- Ne laissez **PAS** les enfants grimper sur le meuble
- Déposez les pièces lourdes sur les tablettes ou tiroirs du bas.
- Lire et suivre toutes les instructions d'assemblage.

PARTS - PIEZAS - PIECES

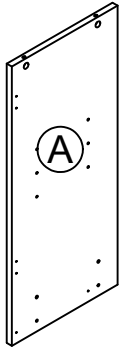

left panel
panel izquierdo
panneau gauche
3508341012

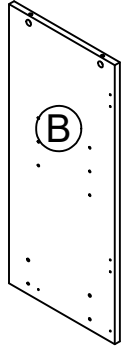

right panel
panel derecho
panneau droit
3508341022

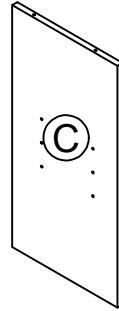

partition
partición
cloison
3508341030



left rear panel
panel trasero izquierdo
pan arrière gauche
3507341051



right rear panel
panel trasero derecho
pan arrière droit
3507341061

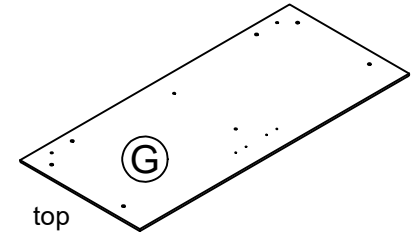

top
cima
dessus
3508341071

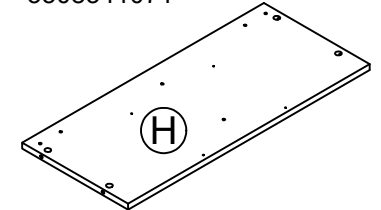

bottom
fondo
fond
3508341082

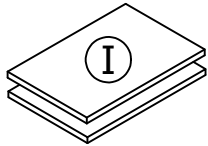

2 adjustable shelves
2 tableros ajustable
2 tablettes ajustable
3508341090

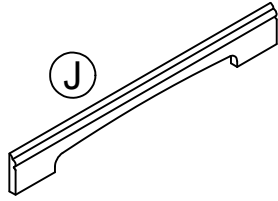

front skirt
barra de frente
barreau avant
3508341100

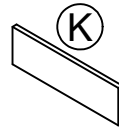

left side skirt
barra izquierdo
barreau gauche
3507341110

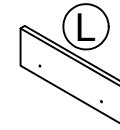

right side skirt
barra derecho
barreau droit
3507341120

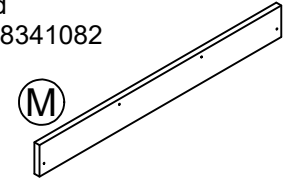

support
soporte
support
350800130

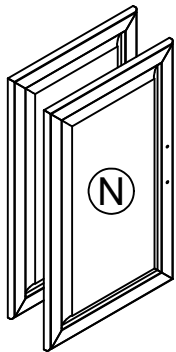

2 doors
2 puertas
2 portes
3508341141

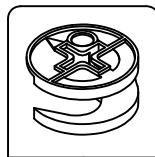

① x10
#A22620
cam lock
cerradura de leva
serrure de came

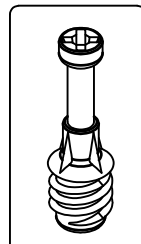

② x10
#A22510
cam bolt
perno de leva
boulon de came

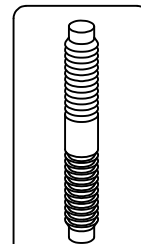

③ x4
#A21520
compression dowel
clavija de compression
goujon de compression

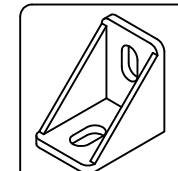

④ x8
#A53510
angle bracket
anaquel del ángulo
support de l'angle

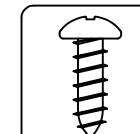

⑤ x32
#A12210
1/2" pan head
cabeza redondo 1/2"
tête ronde

PARTS - PIEZAS - PIECES

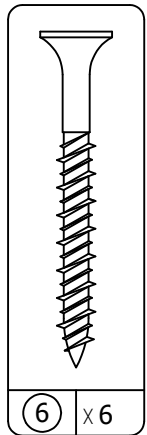

⑥ x 6
#A13410
1 3/4" flat head
cabeza plano 1 3/4"
tête plate 1 3/4"

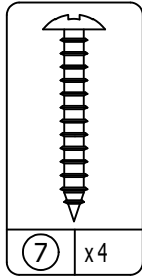

⑦ x 4
#A12850
1" pan head
cabeza redondo 1"
tête ronde 1"

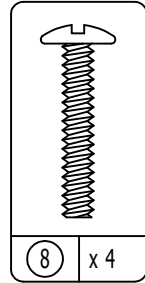

⑧ x 4
#A17400
7/8" machine screw
7/8" tornillo
vis 7/8"

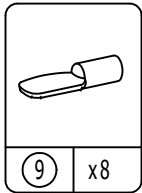

⑨ x 8
#A80250
shelf support
soporte de tablero
support de la tablette

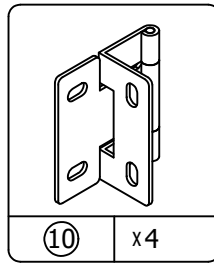

⑩ x 4
#A60010
hinge
bisagra
charnière

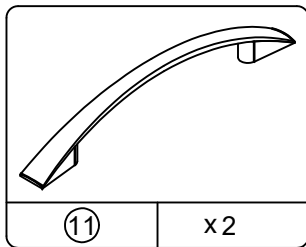

⑪ x 2
#A52395
handle
manija
poignée

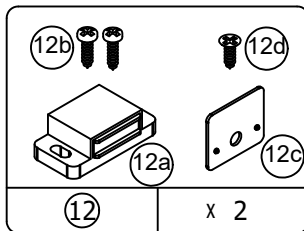

⑫ x 2
#A31000
magnetic catch kit
equipo de la captura magnético
ensemble de loquet magnétique

This illustration shows how the CAM fastening system works.
Esta ilustración muestra el sistema de fijación de leva y como funciona.
Cette illustration montre le système de fixation CAME et son fonctionnement.

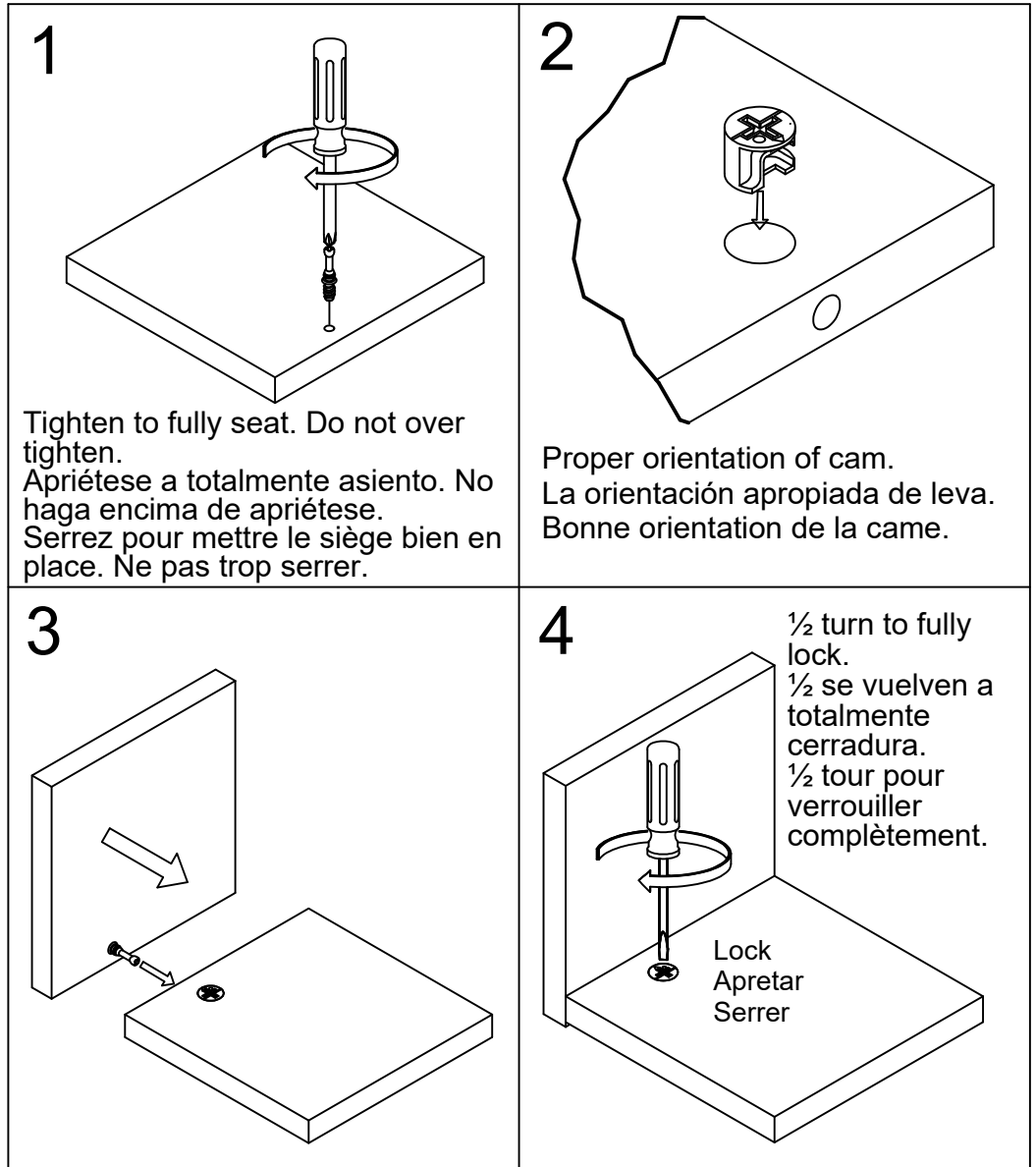

1

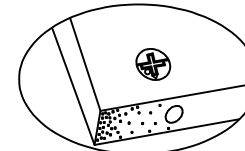
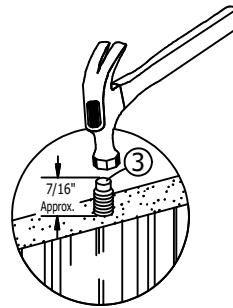
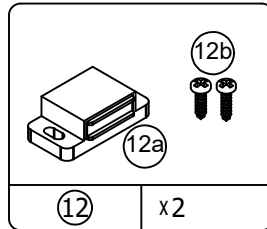
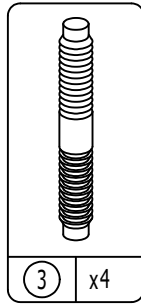
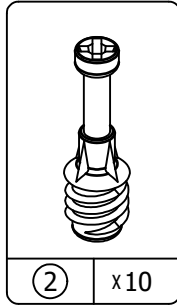
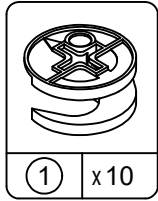

Proper orientation of CAM LOCK
Posición correcta de la cerradura de leva.
Bonne orientation de la SERRURE DE CAME

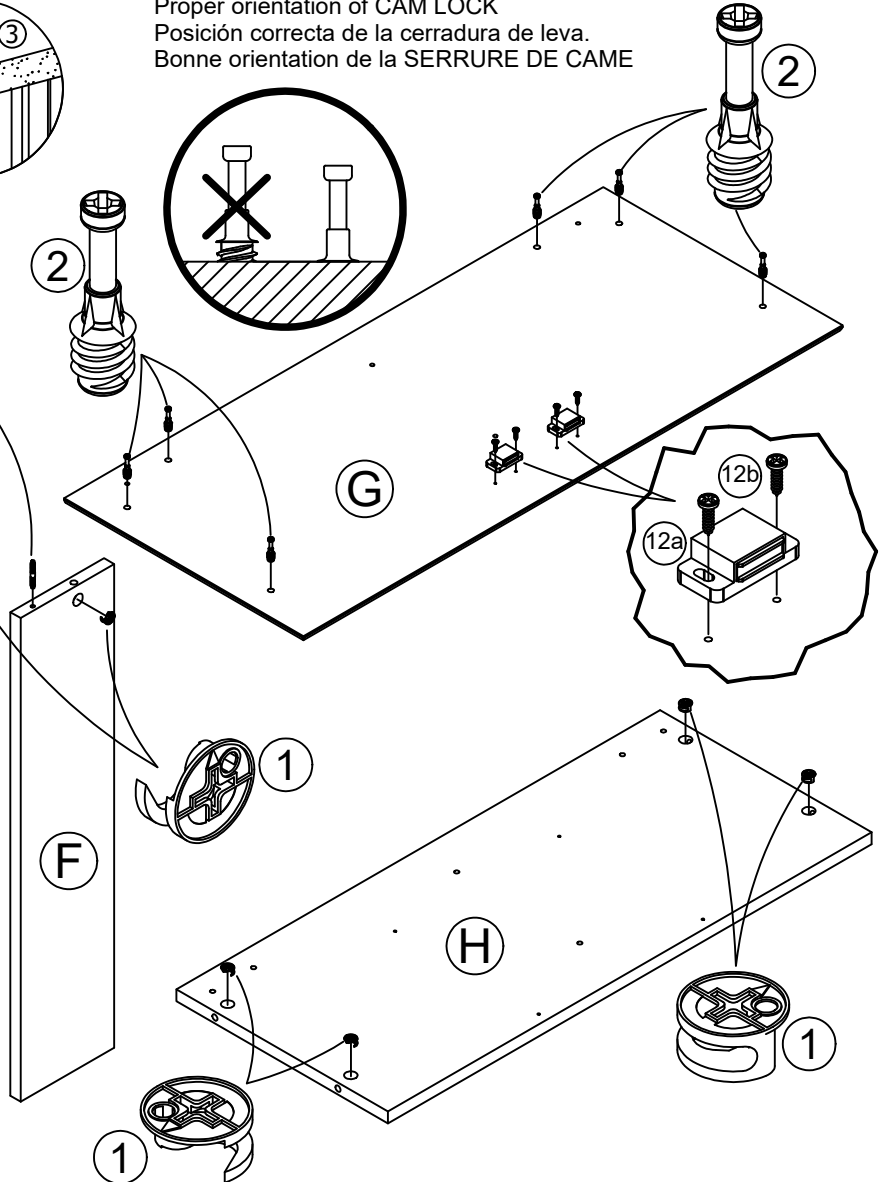
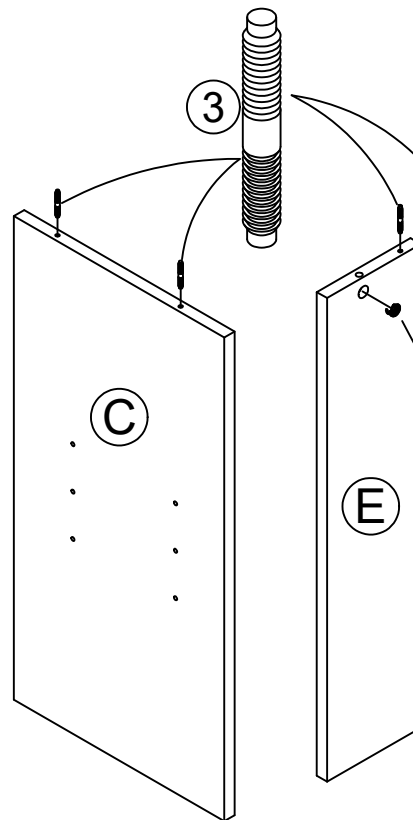
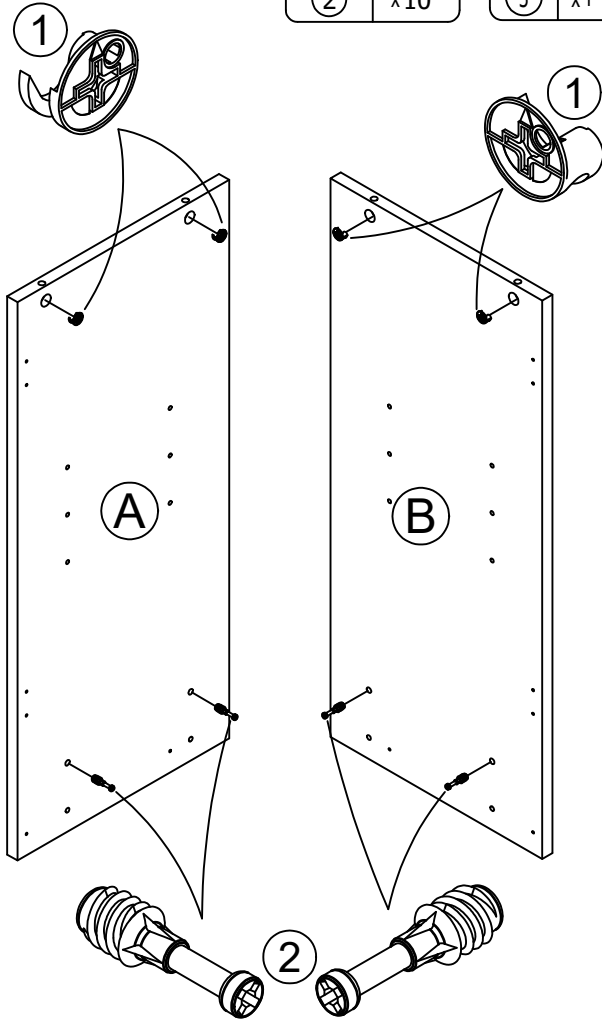

2

Cam locks (1) in panels (E&F) will face down.
Cerraduras (1) en paneles (E y F) se enfrentarán hacia abajo.
Verrous de Cam (1) dans des panneaux (E et F) devra faire face vers le bas.

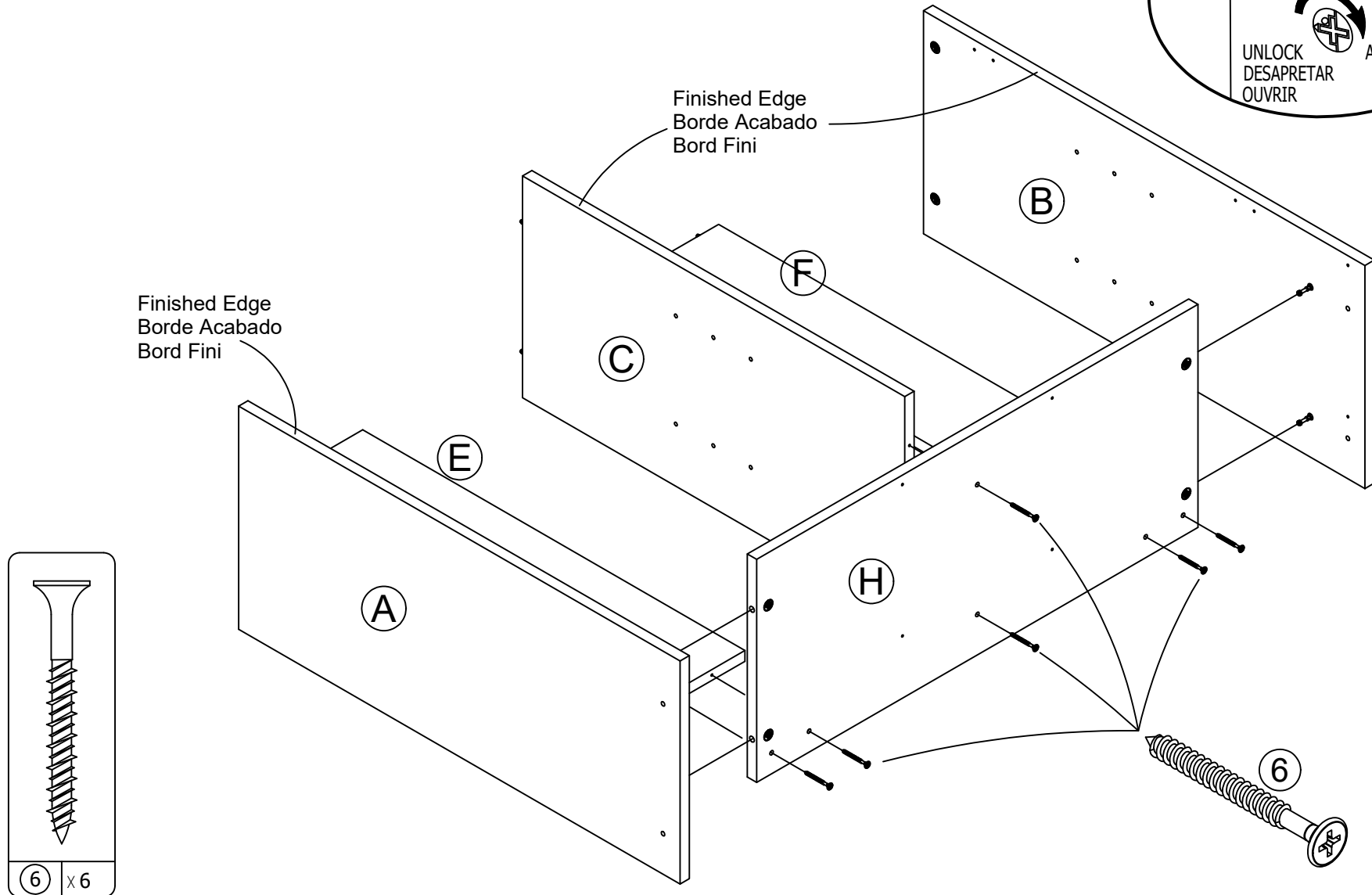
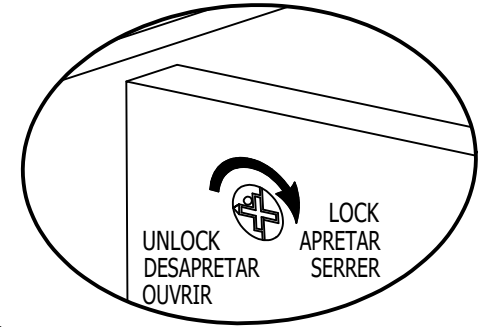

3

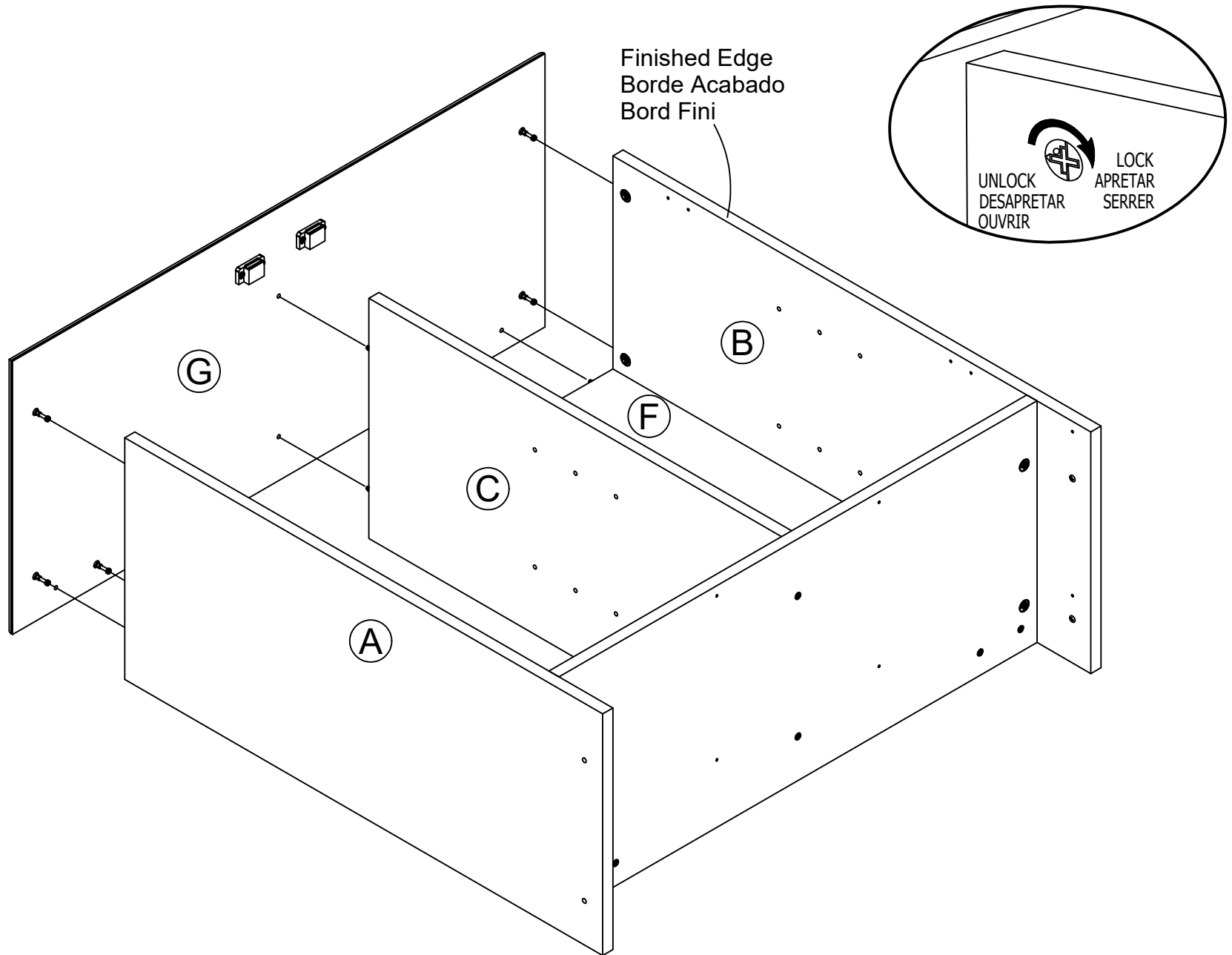

5



5 x16

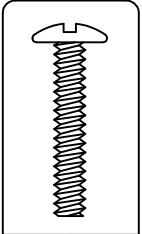

8 x4

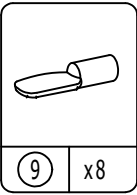

9 x8

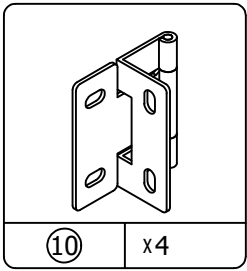

10 x4

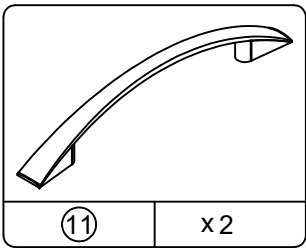

11 x2

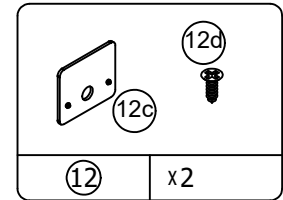

12 x2

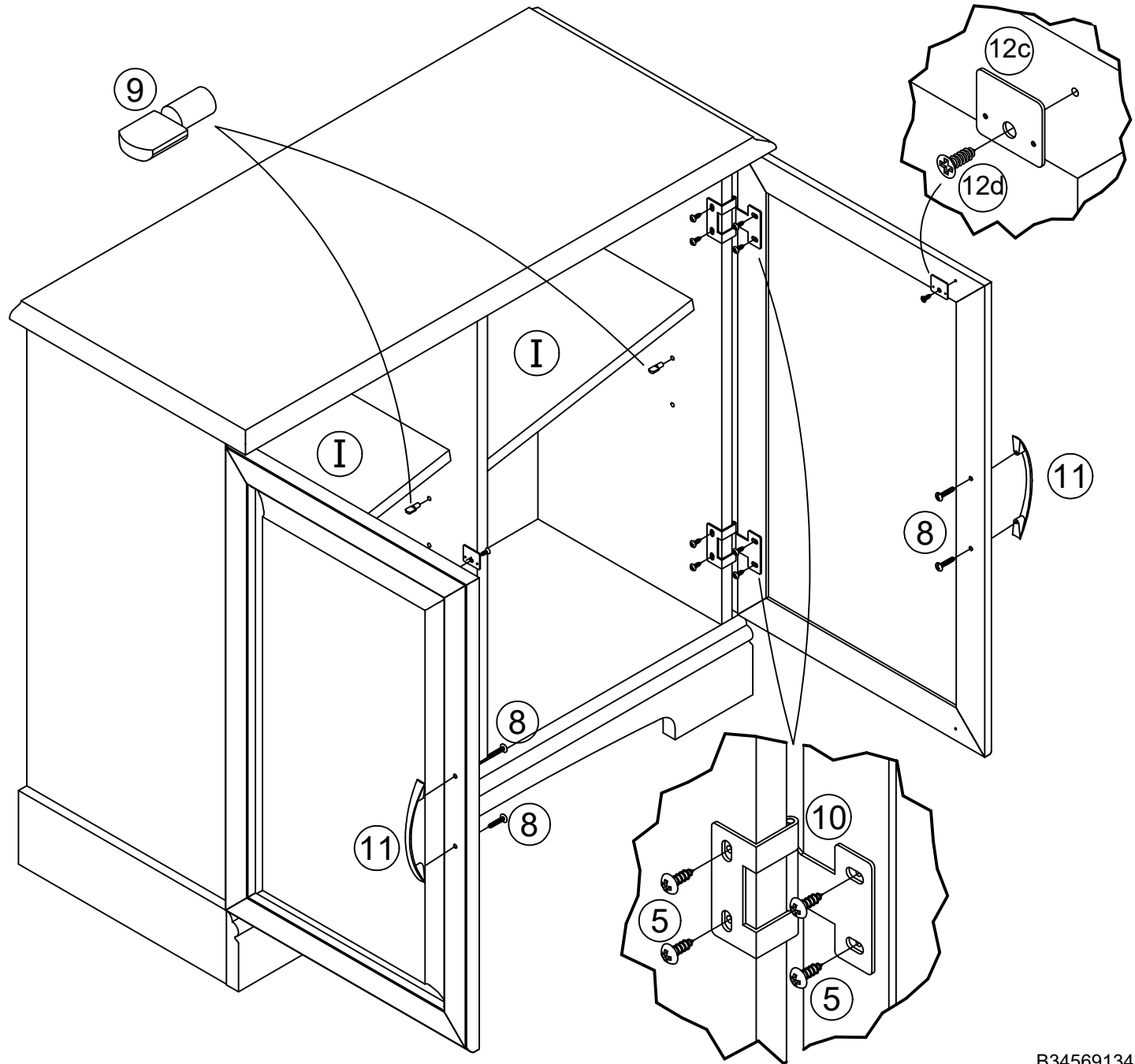

MAXIMUM LOADS – CARGA MAXIMA - CHARGES MAXIMALES

This unit has been designed to support the maximum loads shown. Exceeding these load limits could cause sagging, instability, product collapse, and/or serious injury.

Esta unidad ha sido diseñada para soportar la carga máxima anotada. El exceder estos límites puede causar inestabilidad, colapsarse y/o causar serias lesiones.

Ce meuble a été conçu pour supporter les charges maximales indiquées. En excédant ces limites de charge, le meuble pourrait devenir instable, s'effondrer, et/ou causer des blessures graves.

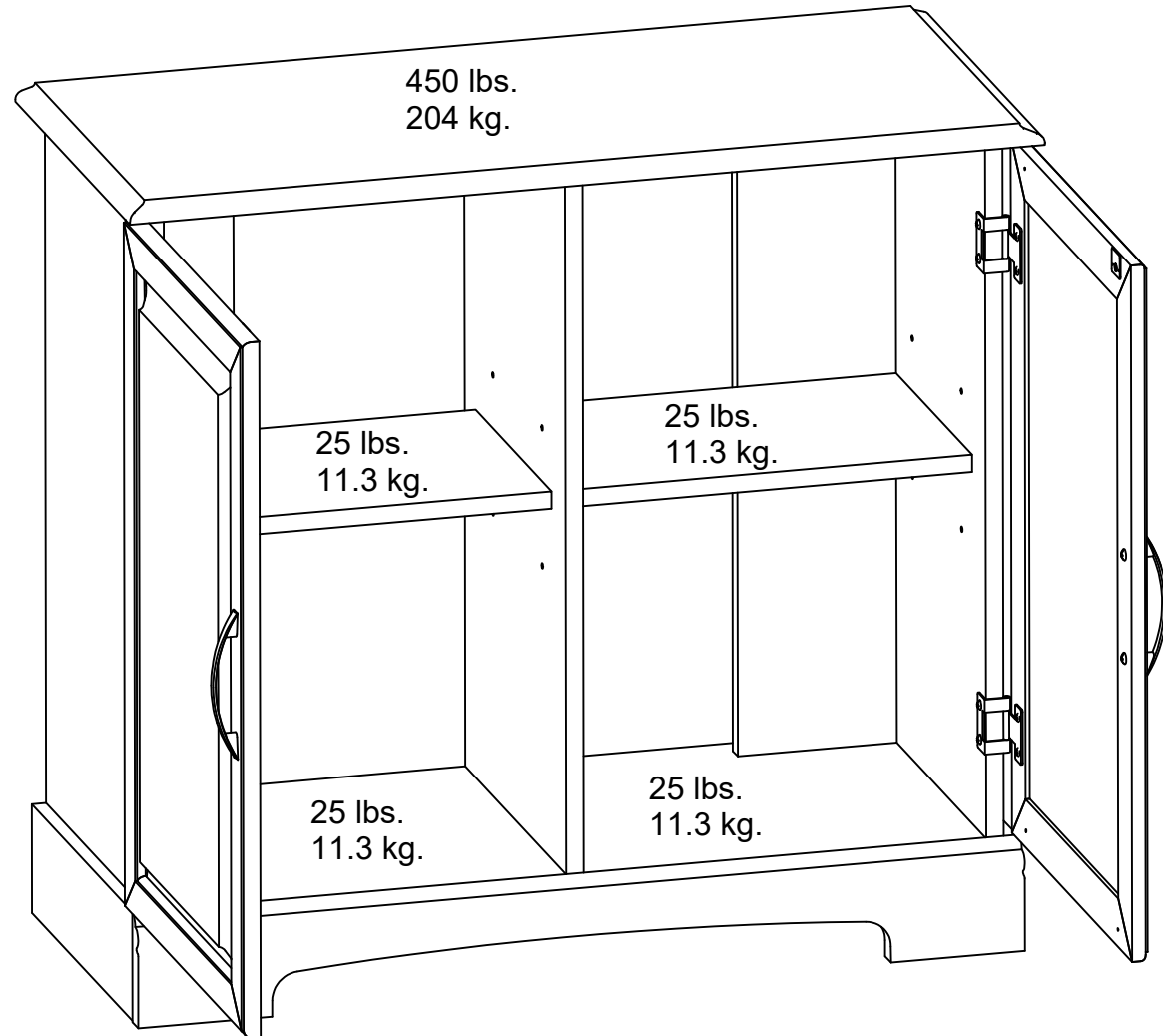

Certificate of Conformity

1. This certificate applies to the Dorel Home Furnishings, Inc. product identified by this instruction manual.
2. This certificate applies to compliance of this product with the CPSC Ban on Lead-Containing Paint (16 CFR 1303).
3. This product is distributed by: Dorel Home Furnishings, Inc.
410 East First Street South
Wright City, MO 63390
636-745-3351
4. Site of Manufacture:
 - Tiffin, OH
5. See front page of instruction manual for date of manufacture.